

# CART SPECIFICATIONS

## 900 SERIES

All cart models are the same size and feature the same capacity.

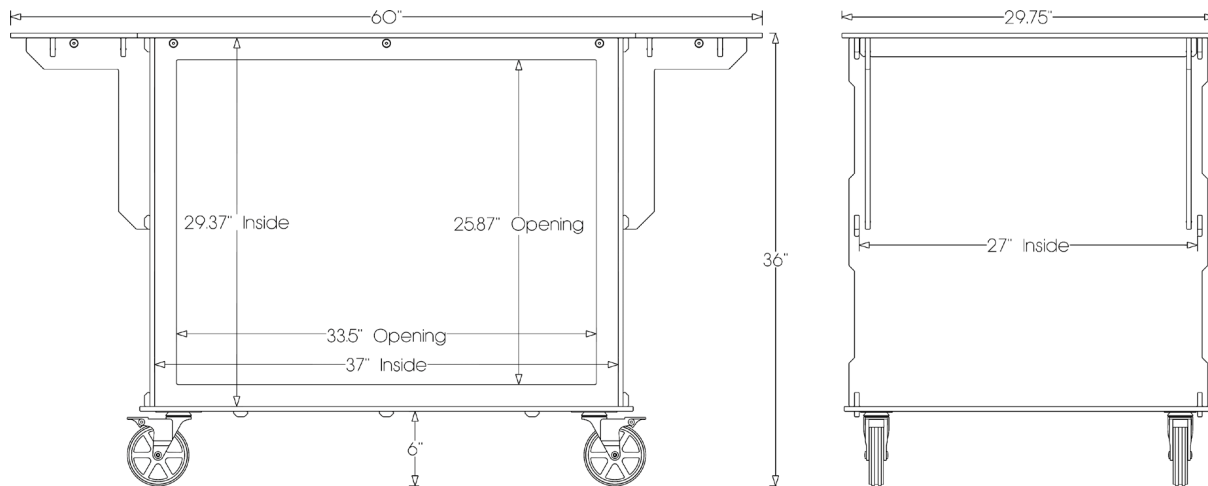

BACK

SIDE

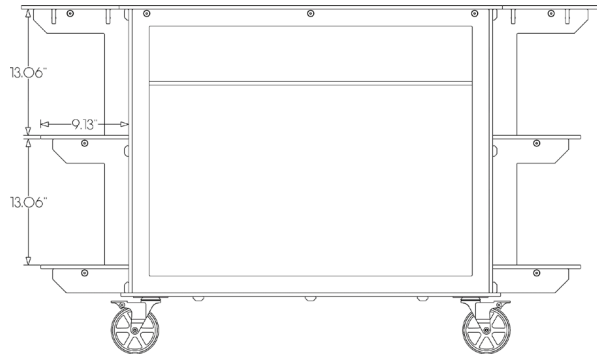

SIDE SHELVES

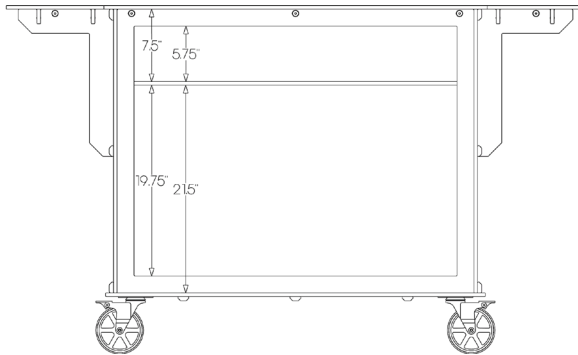

INTERIOR SHELF

Material	Paper Composite
Certifications	NSF Approved Materials
Sustainability	Greenguard, Recycled, and/or FSC Certified Materials
Weight Capacity	400 lbs.
Overall Size (Nominal)	60" Wide x 36" Tall x 29.75" Deep
Wheels	Metal/Aluminum with Locking Mechanism
Weight (Includes Wheels, No Shelves)	132 lbs.
Weight (Interior Shelf, Side Shelves)	Interior Shelf: 19 lbs. / Side Shelves: 30 lbs.