

HUB SPECIFICATIONS

High-capacity pump and accumulator with multiple connection ports.

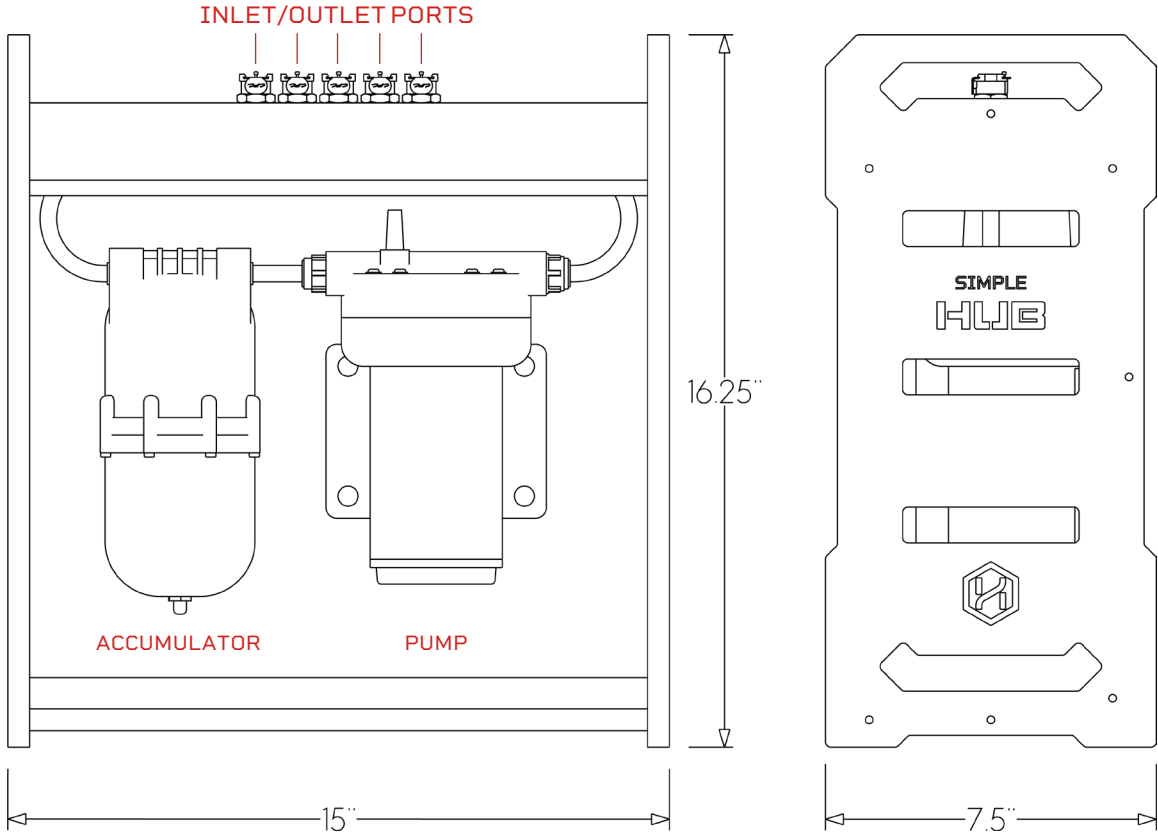

Frame Material	High Density Polyethylene
Capacity	3.2 GPM
Pressure	60 PSI
Voltage/Watts	Voltage:115VAC, Wattage:126W
Tubing	NSF Approved Polyurethane Ether Based
Fittings	CPC Acetal Fittings with Internal Valves
Overall Size	15" Wide x 16.25" Tall x 7.5" Deep
Certifications	NSF or FDA Listed Materials
Total Weight	18 lbs. (8 kg)